

Threaded Thermowells

BIMETAL STEPPED (fits 1/4" diameter elements)

Style ST (Stepped)

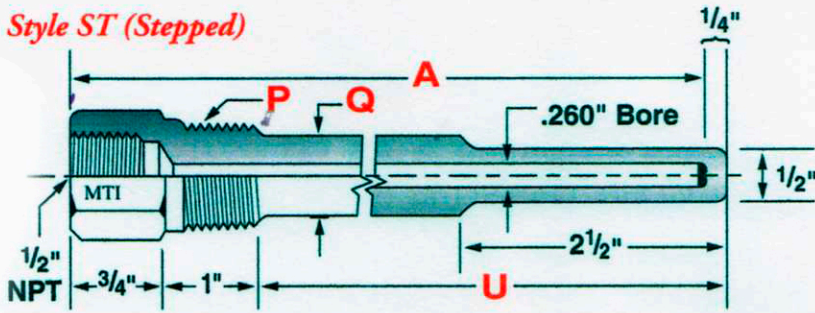

Style H (Extended Lagging)

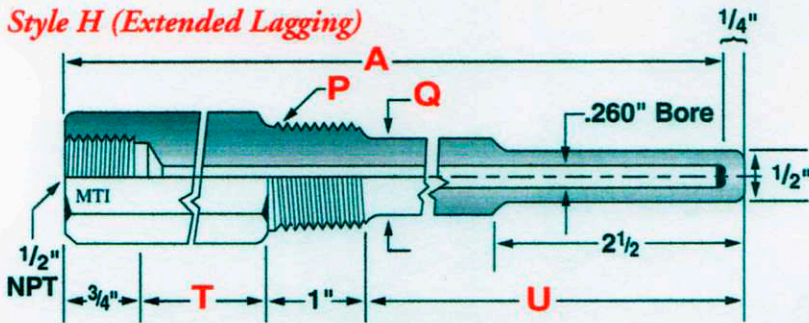

Stepped Shank

P Ext. Thread	Order Code	A Length	U Insertion	Q Shank Dia.
1/2" NPT	100ST	4	2 1/2	1/2
		6	4 1/2	3/8
		9	7 1/2	3/8
		12	10 1/2	3/8
		15	13 1/2	3/8
18	16 1/2	3/8		
3/4" NPT	103ST	4	2 1/2	1/2
		6	4 1/2	3/4
		9	7 1/2	3/4
		12	10 1/2	3/4
		15	13 1/2	3/4
18	16 1/2	3/4		
1" NPT	109ST	4	2 1/2	1/2
		6	4 1/2	7/8
		9	7 1/2	7/8
		12	10 1/2	7/8
		15	13 1/2	7/8
18	16 1/2	7/8		

Stepped (Extended Lagging)

P Ext. Thread	Order Code	A Length	U Insertion	Q Shank Dia.	T
1/2" NPT	H100ST	Determined by T value	2 1/2	1/2	SPECIFY
			4 1/2	3/8	
			7 1/2	3/8	
			10 1/2	3/8	
			13 1/2	3/8	
16 1/2	3/8				
3/4" NPT	H103ST	Determined by T value	2 1/2	1/2	SPECIFY
			4 1/2	3/4	
			7 1/2	3/4	
			10 1/2	3/4	
			13 1/2	3/4	
16 1/2	3/4				
1" NPT	H109ST	Determined by T value	2 1/2	1/2	SPECIFY
			4 1/2	7/8	
			7 1/2	7/8	
			10 1/2	7/8	
			13 1/2	7/8	
16 1/2	7/8				

Standard Insertion Lengths (U) shown...ALL other sizes available.

Easy to Order...

Need Help? (800) 255-5638

103ST

Order
Code #

R

Material

6 1/2"

U

Insertion
Length
(Inches)

- P = 304 SS
- R = 316 SS
- Q = 310 SS
- J = I 600
- B = Brass
- C = Copper
- CS = Carbon Steel
- 0 = Other Alloys

(see page 17)